

# ULTRA PERFORMANCE

**NEW**

**ZAXIS220LC**  
**ULTRA**



# ULTRA PERFORMANCE

# Unmatched Performance

NEW

## ZAXIS ULTRA

In an industry that's always evolving, with growing business demands, customers need a machine they can rely on. An asset to your operation. Committed to its legacy, the all-new ZAXIS 220LC ULTRA is a reliable machine, which is packed with innovative technologies for unparalleled productivity and efficiency. Bringing you quality as standard and so much more. Unlock the full potential of your machine.



### Higher Production with Less Fuel

\*HIOS III hydraulic system and engine control system, thereby reducing CO2 emissions.

### Lower Fuel Consumption in ECO Mode

The ECO mode is a new economical mode that gives high productivity with less fuel and can cut fuel consumption by 10% compared to the PWR mode.

### Rapid Arm Roll-in

Arm roll-in speed increases by combined flow from arm and boom cylinders through regenerative valves for productive excavation.



### Fast Arm Speed During Boom Lowering

In ZAXIS 220LC ULTRA, for boom lowering, pressurized oil from the boom cylinder bottom side is delivered to its rod side, assisted by boom weight. At the same time, pressurized oil from the pump is delivered to the arm cylinder for faster arm movement.

### Powerful Lifting of Material

The Auto Power Lift mode, which automatically surges lifting forces by 6% when needed, allows for powerful lifting.

### Enhanced Power Boost

The enhanced power boost when applied, allows the operator to increase the digging force by 5%. This can be actuated pressing the button on the control lever.

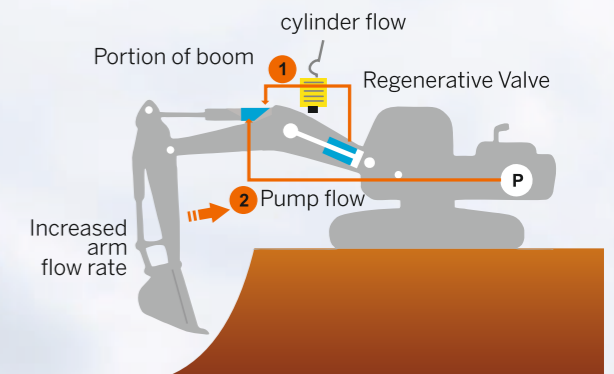

# Limitless Reliability and Durability

# Top-Notch Technology

## State-of-the-art R&D and Quality Control

Tata Hitachi is known for its technological prowess and product performance. The R&D Division has a track record of excellent design, stress analysis expertise using CAE system, and an abundant production data base. A large scale durability test field allows for a series of stringent testing of new machines.



## Rock-Solid, Durable Front Attachment

The robust boom and arm are designed and analysed using advanced software. They are manufactured to precision using high grade steels with state-of-the-art welding robot and machining centres. Thus, durability is built into the front attachment. Arm cylinder and boom cylinders (rod extend ends) cushion shocks at stroke ends to cut noise and extend service life. Joint pins at the front attachment are tightly fit to reduce jolt and sound. The arm-bucket joint is protected by WC thermal spraying on its contact surfaces to reduce wear and jolt.

New type steel bushings, retain grease inside for longer greasing intervals. A reinforced resin thrust plate, provided at front attachment joints, helps reduce wearing noise.

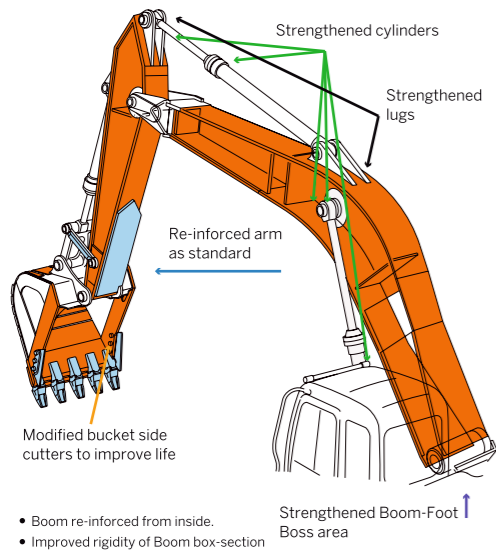

## Strengthened Undercarriage

The X-beam frame is made monolithically with fewer welds for higher rigidity and durability. Idler brackets and travel motor brackets are both reinforced for added durability.



## Proven Upperstructure

Track adjusters absorb impacts to crawlers. Front idlers and adjuster cylinders are integrated to increase durability.

## Reliable and Durable Isuzu Engine

This tried and tested reliable Japanese engine has a track record showing impressive durability at countless tough job sites around the world. This engine with a rugged design, a direct fuel injection system and a robust mechanical governor goes green and complies with global emission norms.

The turbo charged, inter-cooled engine yields a whopping 66kW output for higher production in shorter job schedule.



## Human & Intelligent Operation System (HIOS-III)

Discover excellence with ZAXIS 220LC ULTRA's HIOS-III hydraulic system, developed by industry leading hydraulic technologies and a wealth of experience.

Unleash superior digging forces, swift front movements, faster cycle times and precise controls resulting in higher production with low fuel consumption.

## Generational Intelligence with New Age Micro-processor based controls

Experience advanced micro-processor based technology that enhances productivity, simplifies maintenance, and ensures exceptional performance.

## Versatility

The ZAXIS 220LC ULTRA comes in tailor made options and is easily customizable with various attachments such as Auger, Quick Coupler, Orange Peel Grab and many more.

Option of factory fitted rock breaker piping kit is also available. Wide range of bucket options are also available to suit a variety of applications.



Alicon Rock Breaker



Auger



Orange Peel Grab



# ULTRA PERFORMANCE

## Unmatched Performance

- New Buckets with Higher Capacity **NEW**
- Enhanced Power Boost
- Higher Swing Torque **NEW**
- Auto Power Lift Mode
- Increased Working Ranges **NEW**
- High Production with Low Fuel Consumption
- Faster Cycle Time



## Limitless Reliability and Durability

- Reliable Japanese Engine
- Strengthened Bucket and Boom Cylinders **NEW**
- Strengthened Boom **NEW**
- Strengthened Undercarriage
- Reliable Pump and Motors
- Proven Upper Structure
- Reinforced Front Attachments



## Top-Notch Technology and Versatility

- HIOS III Hydraulic System
- New-age Micro-Processor Based Controls
- ConSite Telematics Suite
- Global e-Service
- Factory fitted rock breaker piping kit
- Easily customizable with attachments, such as, rock breaker, auger, orange peel grab, quick coupler, etc.



## Redefined Comfort and Safety

- 7" LCD Monitor **NEW**
- Auto control Air Conditioner
- Ergonomically Placed Controls
- Suspension Seat
- AM/FM, Bluetooth Music System with Powerful Speakers
- Powerful LED lights **NEW**

### Safety:

- OPG Cabin
- FOPS (Falling Object Protective Structure) Level 2 **NEW**



## Assured Support

- Extended Warranty
- Wide-spread Dealer Network
- Field Diagnostic Vehicle
- Mobile Workshop





### Safe and Robust Cab

- The robust cab, meeting the OPG (Top Guard Level 1) criteria, protects the operator from falling objects.
- Optional enhanced safety and DGMS compliance facility is available:
  - Auto Fire Detection and Suppression System (AFDSS) is available as optional feature and can be factory fitted
  - Auto centralized lubrication system (ACLS) provides lubrication to all the pins
- Swing alarm system can be provided to meet safety requirement
  - Travel alarm to alert nearby equipment/people during travel operation of the machine.

### Cabin Features

- Plush comfortable reclining seat with armrest and adjustable headrest
- Air Lumbar Support
- Air conditioning
- Smooth control levers
- Engine emergency shut-off switch
- Horn function even in machine off condition
- Engine stop switch
- Engine stop cable
- 7" LCD display - multipurpose monitor
- Rear tray
- Bottle holder
- Front guard for cabin glass
- Overhead window
- AM/FM, Bluetooth music system with powerful speakers
- Powerful LED lights

### Comfort-Designed Operator Seat

Experience spacious and ergonomically designed cabin for comfort and productivity, featuring ample space and strategically placed controls for a seamless experience.



New Multi-function Monitor

Ergonomic Control Lever

Drink holder



Emergency engine stop switch

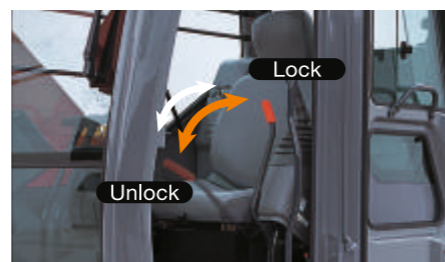

Lever locking and wide door for easy ingress

## EXTENDED WARRANTY

COMPLETE PEACE OF MIND

Genuine Tata Hitachi Parts meet stringent quality standards. These parts are guaranteed to perform and are backed by Tata Hitachi's warranty.

Developed in synergy with our machines, Tata Hitachi ensures wide spread dealer network which also offers Field Diagnostic Vehicle and Mobile Workshop for quicker after-sales service.

Tata Hitachi also offers extended warranty so that our customers get high levels of performance, reliability and peace of mind.

Extended service intervals for reduced maintenance cost:

- Engine oil change: 500 hours
- Engine oil filter change: 500 hours
- Fuel filter change: 500 hours
- Hydraulic oil filter change: 1000 hours
- Hydraulic oil change: 5000 hours



Guaranteed availability - Increased uptime and maximum production.



Higher resale value of equipment after the end of the contract.



Onsite availability of float aggregates.



Fix before failure to ensure maximum reliability of machines.



Trained and experienced manpower at site on 365\*24 hours basis.



Exclusive onsite warehouse for complete contract period.

## ConSite

Consolidated Solution for Construction Sites



### MONTHLY REPORT VIA E-MAIL

Know everything about your machine & how to increase productivity while reducing costs



### SITE EFFICIENCY PARAMETERS

Advises you on ways to fine tune everyday operations



### CAUTION ALARM

Pre-emptive information of your machine's health



### EMERGENCY ALARM

Real time notification to you and the dealer to avoid machine breakdowns



### PERFORMANCE ANALYSIS

Benchmarking your machine against similar class machines in the region



Download the ConSite Pocket app today

✓ Minimise downtime

✓ Support your business



# Specifications

## ENGINE

Model .....Isuzu CC-6BG1T  
 Type .....4-cycle water-cooled, direct injection  
 Aspiration .....Turbocharged, intercooled  
 No. of cylinders .....6  
**Rated power**  
 ISO 9249 / SAE J1349, net .....168 HP (170 PS) at 2 100 min<sup>-1</sup> (rpm)  
 Maximum torque .....637 Nm (65 kgfm) at 1 800 min<sup>-1</sup> (rpm)  
 Piston displacement .....6.494 L  
 Bore and stroke .....105 mm x 125 mm  
 Batteries .....2 x 12 V / 88 Ah

## HYDRAULIC SYSTEM

### Hydraulic Pumps

Main pumps .....2 variable displacement axial piston pumps  
 Maximum oil flow .....2 x 212 L/min  
 Pilot pump .....1 gear pump  
 Maximum oil flow .....33.6 L/min

### Relief Valve Settings

Implement circuit .....350 kgf/cm<sup>2</sup> (34.3 Mpa)  
 Swing circuit .....310 kgf/cm<sup>2</sup> (30.4 Mpa)  
 Travel circuit .....350 kgf/cm<sup>2</sup> (34.3 Mpa)  
 Pilot circuit .....40 kgf/cm<sup>2</sup> (3.9 Mpa)  
 Power boost .....388 kgf/cm<sup>2</sup> (38.0 MPa)

## SERVICE REFILL CAPACITIES

Fuel tank .....400.0 L  
 Engine coolant .....23.0 L  
 Engine oil .....25.0 L  
 Swing device .....6.2 L  
 Travel device (each side) .....6.8 L  
 Hydraulic system .....240.0 L  
 Hydraulic oil tank .....135.0 L

## BACKHOE ATTACHMENTS

| Capacity ISO heaped m <sup>3</sup> | Width                |                   | Tooth Point (no's) | Weight kg | Max. Material Density (kg/m <sup>3</sup> ) | Arm Length (m) |
|------------------------------------|----------------------|-------------------|--------------------|-----------|--|----------------|
|                                    | Without side cutters | With side cutters |                    |           |  |                |
| 0.9 GP                             | 1 130 mm             | 1 240 mm          | 5                  | 745       | Heavy-Duty Services                        | 2.9            |
| 1.0 HD                             | 1 245 mm             | 1 269 mm          | 4                  | 962       | 2 000                                      | 2.4            |
| 1.1 GP                             | 1 330 mm             | 1 440 mm          | 6                  | 929       | 1 800                                      | 2.4            |
| 1.22 ELM                           | 1 460 mm             | 1 570 mm          | 6                  | 857       | 1 100                                      | 2.4            |
| Block Handling                     | 1 236 mm             | -                 | 4                  | 1 240     | G&M  | 2.4            |
| 1.7                                | 1 802 mm             | -                 | -                  | 799       | 1 150                                      | 2.4            |

G & M - Granite and Marbel

## WORKING RANGES

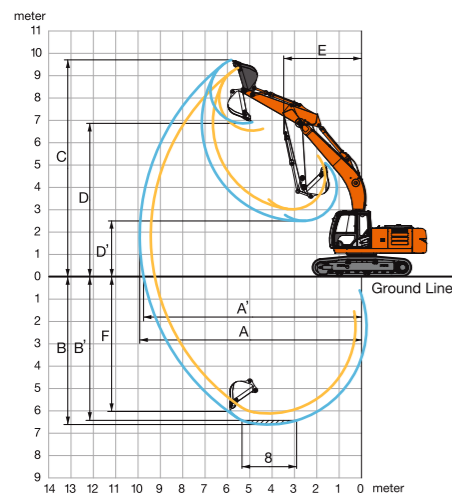

|             |                                    | Unit: mm |        |
|-------------|------------------------------------|----------|--------|
| Boom length |                                    | 5.68 m   |        |
| Arm length  |                                    | 2.4 m    | 2.9 m  |
| A           | Max. digging reach                 | 9 435    | 9 930  |
| A'          | Max. digging reach (on ground)     | 9 260    | 9 760  |
| B           | Max. digging depth                 | 6 160    | 6 630  |
| B'          | Max. digging depth for 2.5 m level | 5 950    | 6 470  |
| C           | Max. cutting height                | 9 700    | 10 070 |
| D           | Max. dumping height                | 6 870    | 7 200  |
| D'          | Min. dumping height                | 3 180    | 2 630  |
| E           | Min. swing radius                  | 3 180    | 3 190  |
| F           | Max. vertical wall digging depth   | 5 720    | 6 140  |

## UNDER CARRIAGE

### Tracks

Heat-treated connecting pins with dirt seals Hydraulic (grease) track adjusters with shock-absorbing recoil springs.

### Numbers of Rollers and Shoes on Each Side

Upper roller .....2  
 Lower roller .....8  
 Track shoes .....49  
 Track guard .....4

### Travel Device

Each track driven by 2-speed axial piston motor.  
 Parking brake is spring-set/hydraulic-released disc type.  
 Automatic transmission system: High-Low.  
 Travel speeds .....High : 0 to 5.1 km/h  
 .....Low : 0 to 3.5 km/h  
 Maximum traction force .....184 kN (18 800 kgf)  
 Gradeability .....70% (35 degree) continuous

## UPPER STRUCTURE

Swing speed .....12.2 min<sup>-1</sup>(rpm)  
 Swing torque .....65.1 kNm (6 638 kgfm)

## BUCKET AND ARM DIGGING FORCES

| Arm length                       | 2.4 m (STD)         | 2.91 m              |
|----------------------------------|---------------------|---------------------|
| Bucket digging force* ISO        | 158 kN (16 100 kgf) | 158 kN (16 100 kgf) |
| Bucket digging force* SAE : PCSA | 139 kN (14 200 kgf) | 139 kN (14 200 kgf) |
| Arm crowd force* ISO             | 139 kN (14 200 kgf) | 114 kN (11 600 kgf) |
| Arm crowd force* SAE : PCSA      | 133 kN (13 600 kgf) | 110 kN (11 200 kgf) |

\* At Power Boost

# Specifications

## DIMENSIONS

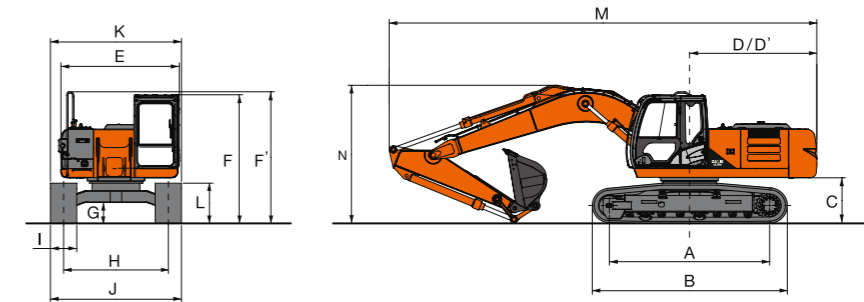

ZX220LC (STD/HD) Unit: mm

|    |                                  |       |
|----|----------------------------------|-------|
| A  | Distance between tumbler         | 3 660 |
| B  | Undercarriage length             | 4 460 |
| *C | Counterweight clearance          | 1 040 |
| D  | Rear-end swing radius            | 2 910 |
| D' | Rear-end length                  | 2 910 |
| E  | Overall width of upperstructure  | 2 700 |
| F  | Overall height of cab            | 2 940 |
| F' | Overall height of upperstructure | 3 010 |
| *G | Min. ground clearance            | 450   |

|    |  |   |
|----|--|---|
| H  | Track gauge                            | 2 390   |
| I  | Track shoe width                       | 600   |
| J  | Undercarriage width                    | 2 990   |
| K  | Overall width                          | 2 990   |
| *L | Track height with triple grouser shoes | 920   |
| M  | Overall length                         | With 2.4 m arm<br>9 750<br>With 2.9m arm<br>9 750 |
| N  | Overall height of boom                 | With 2.4 m arm<br>3 030<br>With 2.9m arm<br>3 070 |

\* Excluding track shoe lug G: Triple grouser shoe

## WEIGHTS AND GROUND PRESSURE

| Shoe type         | Shoe width | Arm length | ZX220LC (STD) *1 |                            | ZX220LC (HD) *2 |                            |
|-------------------|------------|------------|------------------|----------------------------|-----------------|----------------------------|
|                   |            |            | kg               | kPa (kgf/cm <sup>2</sup> ) | kg              | kPa (kgf/cm <sup>2</sup> ) |
| Triple grouser    | 600 mm     | 2.4 m      | 21 200           | 48 (0.49)                  | 21 300          | 48 (0.49)                  |
|                   |            | 2.91 m     | 21 400           | 49 (0.50)                  | 21 500          | 48 (0.49)                  |
| Triple grouser HD | 600 mm     | 2.4 m      | 21 400           | 49 (0.50)                  | 21 500          | 49 (0.50)                  |
|                   |            | 2.91 m     | 21 600           | 49 (0.50)                  | 21 700          | 49 (0.50)                  |

\*1: Including 1.1 m<sup>3</sup> (ISO heaped) bucket weight (STD: 929 kg) and counterweight (4 600 kg). | \*2: Including 1.0 m<sup>3</sup> (ISO heaped) bucket weight (HD: 962 kg) and counterweight (4 600 kg).

## LIFTING CAPACITIES

Notes: 1. Ratings are based on ISO 10567.

2. Lifting capacity does not exceed 75% of tipping load with the machine on firm, level ground or 87% full hydraulic capacity.

3. The load point is the center-line of the bucket pivot mounting pin on the arm.

4. \*Indicates load limited by hydraulic capacity.

For lifting capacities, subtract bucket and quick hitch weight from lifting capacities without bucket.

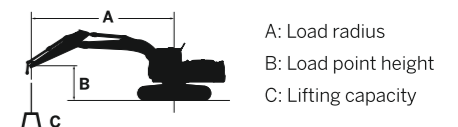

## ZX220LC (STD/HD)

| Conditions             | Load point height m | Load radius       |                                 |                   |                                 |                   |                                 |                   |                                 |                   |                                 | At maximum reach  |                                 |       |  |  |  |  |
|------------------------|---------------------|-------------------|---------------------------------|-------------------|---------------------------------|-------------------|---------------------------------|-------------------|---------------------------------|-------------------|---------------------------------|-------------------|---------------------------------|-------|--|--|--|--|
|                        |                     | 1.5 m             |                                 | 3.0 m             |                                 | 4.5 m             |                                 | 6.0 m             |                                 | 7.5 m             |                                 | meter             |                                 |       |  |  |  |  |
|                        |                     | Rating over-front | Rating over-side or 360 degrees | Rating over-front | Rating over-side or 360 degrees | Rating over-front | Rating over-side or 360 degrees | Rating over-front | Rating over-side or 360 degrees | Rating over-front | Rating over-side or 360 degrees | Rating over-front | Rating over-side or 360 degrees | meter |  |  |  |  |
| Boom 5.68 m            | 6.0                 |                   |                                 |                   |                                 |                   |                                 |                   |                                 |                   |                                 |                   |                                 |       |  |  |  |  |
| Arm 2.4 m              | 4.5                 |                   |                                 |                   |                                 |                   |                                 |                   |                                 |                   |                                 |                   |                                 |       |  |  |  |  |
| Counterweight 4 600 kg | 3.0                 |                   |                                 |                   |                                 |                   |                                 |                   |                                 |                   |                                 |                   |                                 |       |  |  |  |  |
| Shoe width: 600 mm     | 1.5                 |                   |                                 |                   |                                 |                   |                                 |                   |                                 |                   |                                 |                   |                                 |       |  |  |  |  |
|                        | 0 (Ground)          |                   |                                 |                   |                                 |                   |                                 |                   |                                 |                   |                                 |                   |                                 |       |  |  |  |  |
|                        | -1.5                |                   |                                 |                   |                                 |                   |                                 |                   |                                 |                   |                                 |                   |                                 |       |  |  |  |  |
|                        | -3.0                |                   |                                 |                   |                                 |                   |                                 |                   |                                 |                   |                                 |                   |                                 |       |  |  |  |  |
|                        | -4.5                |                   |                                 |                   |                                 |                   |                                 |                   |                                 |                   |                                 |                   |                                 |       |  |  |  |  |

## ZX220LC (Optional)

| Conditions             | Load point height m | Load radius       |                                 |                   |                                 |                   |                                 |                   |                                 |                   |                                 | At maximum reach  |                                 |       |  |  |  |  |
|------------------------|---------------------|-------------------|---------------------------------|-------------------|---------------------------------|-------------------|---------------------------------|-------------------|---------------------------------|-------------------|---------------------------------|-------------------|---------------------------------|-------|--|--|--|--|
|                        |                     | 1.5 m             |                                 | 3.0 m             |                                 | 4.5 m             |                                 | 6.0 m             |                                 | 7.5 m             |                                 | meter             |                                 |       |  |  |  |  |
|                        |                     | Rating over-front | Rating over-side or 360 degrees | Rating over-front | Rating over-side or 360 degrees | Rating over-front | Rating over-side or 360 degrees | Rating over-front | Rating over-side or 360 degrees | Rating over-front | Rating over-side or 360 degrees | Rating over-front | Rating over-side or 360 degrees | meter |  |  |  |  |
| Boom 5.68 m            | 6.0                 |                   |                                 |                   |                                 |                   |                                 |                   |                                 |                   |                                 |                   |                                 |       |  |  |  |  |
| Arm 2.91 m             | 4.5                 |                   |                                 |                   |                                 |                   |                                 |                   |                                 |                   |                                 |                   |                                 |       |  |  |  |  |
| Counterweight 4 600 kg | 3.0                 |                   |                                 |                   |                                 |                   |                                 |                   |                                 |                   |                                 |                   |                                 |       |  |  |  |  |
| Shoe width: 600 mm     | 1.5                 |                   |                                 |                   |                                 |                   |                                 |                   |                                 |                   |                                 |                   |                                 |       |  |  |  |  |
|                        | 0 (Ground)          |                   |                                 |                   |                                 |                   |                                 |                   |                                 |                   |                                 |                   |                                 |       |  |  |  |  |
|                        | -1.5                |                   |                                 |                   |                                 |                   |                                 |                   |                                 |                   |                                 |                   |                                 |       |  |  |  |  |
|                        | -3.0                |                   |                                 |                   |                                 |                   |                                 |                   |                                 |                   |                                 |                   |                                 |       |  |  |  |  |
|                        | -4.5                |                   |                                 |                   |                                 |                   |                                 |                   |                                 |                   |                                 |                   |                                 |       |  |  |  |  |

# Equipment

| ZX220LC ULTRA  | STD | HD |
|--|-----|----|
| <b>ENGINE</b>  |     |    |
| Air cleaner double filters   | ●   | ●  |
| Auto idle system   | ●   | ●  |
| Cartridge-type engine oil filter   | ●   | ●  |
| Cartridge-type fuel pre-filter   | ●   | ●  |
| Cartridge-type fuel main filter  | ●   | ●  |
| Dry-type air filter with evacuator valve (with air filter restriction indicator) | ●   | ●  |
| ECO/PWR mode control   | ●   | ●  |
| Fan guard  | ●   | ●  |
| Water separator  | ●   | ●  |
| Pre-cleaner  | ●   | ●  |
| Dust-Proof indoor net  | ●   | ●  |
| Radiator reserve tank  | ●   | ●  |
| 50 A alternator  | ●   | ●  |
| <b>HYDRAULIC SYSTEM</b>  |     |    |
| Auto power lift  | ●   | ●  |
| Control valve with main relief valve   | ●   | ●  |
| Full-flow filter   | ●   | ●  |
| High mesh full flow filter with restriction indicator                            | ○   | ○  |
| Pilot filter   | ●   | ●  |
| Power boost  | ●   | ●  |
| Suction filter   | ●   | ●  |
| Extra port for control valve   | ●   | ●  |
| Work mode selector   | ●   | ●  |
| <b>CAB</b>   |     |    |
| All-weather sound suppressed steel cab   | ●   | ●  |
| AM-FM radio with 2 speakers  | ●   | ●  |
| Ashtray  | ●   | ●  |
| Auto control air conditioner   | ●   | ●  |
| Drink holder   | ●   | ●  |
| Drink holder with hot & cool   | ●   | ●  |
| Electric horn  | ●   | ●  |
| Engine shut-off lever  | ●   | ●  |
| Evacuation hammer  | ●   | ●  |
| Floor mat  | ●   | ●  |
| Footrest   | ●   | ●  |
| Front window washer  | ●   | ●  |
| Front windows on upper, lower and left side can be opened                        | ●   | ●  |
| Lower cab front guard  | ●   | ●  |
| Upper cab front guard  | ●   | ●  |
| Hot & cool box   | ●   | ●  |
| Intermittent windshield wipers   | ●   | ●  |
| Room light   | ●   | ●  |
| FOPS Level 1 compliant cabin   | ●   | ●  |
| FOPS Level 2 compliant cabin with top guard (IS/ISO 3449/ ISO 10262)             | ○   | ○  |
| Pilot control shut-off lever   | ●   | ●  |
| Seat belt with warning system  | ●   | ●  |
| Radio antenna  | ●   | ●  |
| AUX port   | ●   | ●  |
| Seat: Mechanical suspension seat with air lumbar support                         | ●   | ●  |
| Seat adjustment : backrest, armrest, height and angle, slide forward / back      | ●   | ●  |
| Short wrist control levers   | ●   | ●  |
| 4 fluid-filled elastic mounts  | ●   | ●  |
| <b>LIGHTS</b>  |     |    |
| Additional cab roof front lights   | ●   | ●  |
| Additional boom light (right side)   | ○   | ○  |
| 2 working lights (boom left side, tool box)                                      | ●   | ●  |
| Light on the counter weight  | ●   | ●  |

| ZX220LC ULTRA  | STD | HD |
|--|-----|----|
| <b>MONITOR SYSTEM</b>  |     |    |
| Meters : Hr meter, breaker hour meter engine coolant, temperature gauge and fuel gauge   | ●   | ●  |
| Warning indicators : Alternator charge, engine oil pressure, engine overheat, air filter restriction, low fuel level, engine preheat | ●   | ●  |
| Indicators : Engine preheat, work modes, auto idle work light and fuel consumption   | ●   | ●  |
| Alarm buzzers : Low engine oil pressure and engine overheat  | ●   | ●  |
| On board display of Radio & Air conditioner  | ●   | ●  |
| <b>UPPER STRUCTURE</b>   |     |    |
| Electric fuel refilling pump with auto stop function   | ●   | ●  |
| Fuel Level Float   | ●   | ●  |
| Hydraulic oil level gauge  | ●   | ●  |
| Rear view mirror (right & left side)   | ●   | ●  |
| Swing parking brake  | ●   | ●  |
| Tool box   | ●   | ●  |
| Undercover   | ●   | ●  |
| Utility space (behind cabin)   | ●   | ●  |
| <b>UNDERCARRIAGE</b>   |     |    |
| Bolt-on sprocket   | ●   | ●  |
| Reinforced track links with pin seals  | ●   | ●  |
| Reinforced idler bracket   | ●   | ●  |
| Travel motor covers  | ●   | ●  |
| Travel parking brake   | ●   | ●  |
| Track guard (each side) and hydraulic track adjuster   | ●   | ●  |
| Upper and lower rollers  | ●   | ●  |
| 2 track guards   | ●   | ●  |
| 4 tie down hooks   | ●   | ●  |
| 600 mm triple grouser shoes  | ●   | ○  |
| 600 mm HD triple grouser shoes   | ○   | ●  |
| 800 mm triple grouser shoes  | ○   | ●  |
| <b>FRONT ATTACHMENTS</b>   |     |    |
| Centralized lubrication system   | ○   | ○  |
| Dirt seal on all bucket pins   | ●   | ●  |
| Flanged pin  | ●   | ●  |
| Reinforced link B  | ●   | ●  |
| WC (tungsten-carbide) thermal spraying   | ●   | ●  |
| Seat screws for breaker attachment   | ●   | ●  |
| <b>ATTACHMENTS</b>   |     |    |
| Breaker and crusher piping   | ○   | ○  |
| High mesh full flow filter with restriction indicator  | ○   | ○  |
| Parts for breaker and crusher  | ○   | ○  |
| Line filter  | ○   | ○  |
| <b>MISCELLANEOUS</b>   |     |    |
| Auto Lubrication   | ○   | ○  |
| Lockable fuel refilling cap  | ●   | ●  |
| Lockable machine covers  | ●   | ●  |
| Onboard information controller   | ●   | ●  |
| Skid-resistant tapes, plates and handrails   | ●   | ●  |
| Standard tool kit  | ●   | ●  |
| Travel direction mark on track frame   | ●   | ●  |
| Global e-Service   | ●   | ●  |
| Battery Cut-off Switch   | ●   | ●  |
| Travel alarm   | ○   | ○  |
| Swing alarm  | ○   | ○  |
| AFSS phase-I   | ○   | ○  |
| Rear view camera   | ○   | ○  |

Standard and optional equipment may vary by country, so please consult your Tata Hitachi dealer for details.

● : Standard equipment ○ : Optional equipment

## Tata Hitachi Construction Machinery Company Private Limited

Registered Office: Jubilee Building, 45 Museum Road, Bangalore, India 560025  
Telephone: +918066953301 / 02 / 03 / 04 / 05 | Email: info@tatahitachi.co.in



Authorised Dealer

These specifications are subject to change without prior notice. The machine depicted may vary from the actual machine. Please contact our nearest office for latest specifications. Accessories shown here are not part of the standard equipment. Performance of the machine may vary with site and operating conditions encountered.