

SUPER LONG REACH

SPEND LESS. EARN MORE.

Experience The Prime Advantage

EX215LC-SLR
PRIME





- LED lights **NEW**



- Integrated rear view camera **NEW**
- 7" TFT LCD monitor with detailed monitoring parameters **NEW**
- Maintenance and alerts on monitor **NEW**



- 4G telematics system **NEW**
- Daily SMS
- App and web based monitoring



- Battery Cut-off switch **NEW**
- Option of swing and travel alarms
- Beacon lights
- CLS, AFDSS and other safety features



- 30% smoother pilot levers **NEW**
- Comfortable and roomy cabin
- Weight adjustable suspension seat
- Air lumbar support in operator seat **NEW**
- Seat belt, fan and air conditioning
- Bluetooth music system



- Boom & arm regeneration
- Cross sensing summation system



- Sturdier bucket cylinder with metallic cap for seal protection **NEW**
- Casted H-link **NEW**



- Bigger Bucket 0.5 m³ **NEW**



- Cyclonic air pre-cleaner
- Dust proof indoor net
- Fuel shut off solenoid **NEW**
- Improved ROC **NEW**
- Extended service intervals:
 - Hydraulic oil change: 4500 hours
 - Hydraulic filter change: 1500 hours



- Intelligent Optimum Hydraulic System (IOHS)
- High efficiency hydraulic pump **NEW**
- New-generation control valve
- Hitachi's proven hydraulics for powerful performance
- Improved swing device **NEW**



- HD undercarriage
- HD track chain
- 10.5 mm shoe thickness
- 600 mm / 800 mm track shoe options available



- Front guard
- LED light
- LCD monitor
- Front wiper
- Sun shade
- Auto idle
- Rear view mirror
- 3 power modes
- USB charging port
- Air conditioning
- Beeper / Buzzer
- Bluetooth music system
- Seat with air lumbar support
- Battery Cut-Off switch
- Seat belt with alarm
- InSite - 4G telematics



- Beacon light
- Travel Alarm
- Swing alarm
- Cold start kit
- CLS, AFDSS
- Hydraulic flow restriction indicator
- 2 work light on boom
- Counter weight light
- FOPS frame guard
- Fuel refilling pump
- Rear view camera

SPECIFICATIONS

ENGINE

Model	Cummins 6BT5.9C
Type.....	6 cylinder water cooled, direct injection
Rated fly wheel power	140 HP @ 2000 rpm
Max.torque.....	57.7 kgf-m @ 1600 rpm
Batteries	2x12V

HYDRAULIC SYSTEM

Main pumps	2 variable displacements axial piston pumps
Flow rate	2x221 L/min
Pilot pump.....	1 gear pump
Flow rate.....	20 L/min

SUPERSTRUCTURE

Swing Speed	13.3 rpm
-------------------	----------

RELIEF VALVE SETTINGS

Implement circuit	285 kgf/cm ²
Swing circuit.....	275 kgf/cm ²
Travel circuit.....	350 kgf/cm ²
Pilot circuit	40 kgf/cm ²

UNDERCARRIAGE

Travel Speed.....	0-4.2 kmph
Max. traction force	15,200 kgf
Gradeability	35° (70% continuous)
No. of upper rollers.....	2
No. of lowers rollers.....	8
No. of track shoes	52
Shoe width	600/800 mm

SERVICE REFILL CAPACITIES

Hydraulic tank.....	129.0 ltr
Hydraulic system	220.0 ltr
Fuel tank.....	300.0 ltr
Engine coolant.....	25.0 ltr
Engine oil	22.0 ltr
Swing device	6.7 ltr
Travel device (Each side)	6.8 ltr

WEIGHTS AND GROUND PRESSURE

Track width	Operating weight	Ground pressure
600 mm	21,800 kg	0.51 kgf/cm ²
800 mm	22,200 kg	0.39 kgf/cm ²

BUCKETS

Capacity ISO Heaped	Width (mm)		Tooth Points (nos.)	Weight (kg)	Max. Material density (kg/m ³)	Arm length (m)
	With out Side Cutter	With Side Cutter				
0.5 m ³	813	933	4	470	1800	6.37

WORKING RANGES

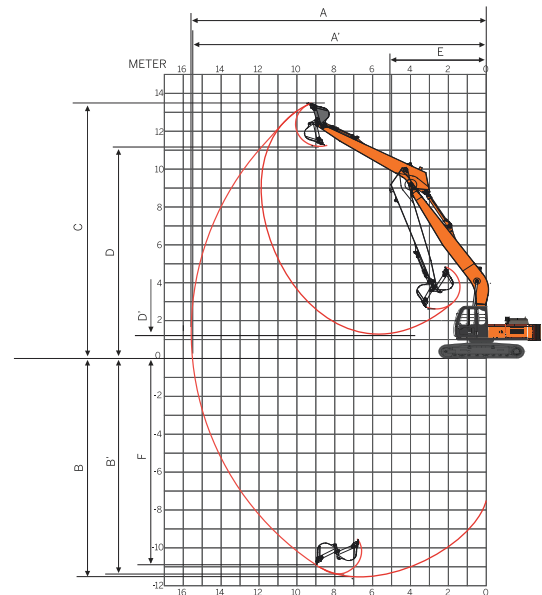

	Boom	8.23 m
	Arm	6.37 m
A	Max. digging reach	15,560
A'	Max. digging reach (on ground)	15,452
B	Max. digging depth	11,628
B'	Max. digging depth (8' level)	11,524
C	Max. cutting height	13,465
D	Max. dumping height	11,171
D'	Min. dumping height	1,368
E	Min. swing radius	5,040
F	Max. vertical wall depth	10,832

All dimensions are in mm

DIMENSIONS

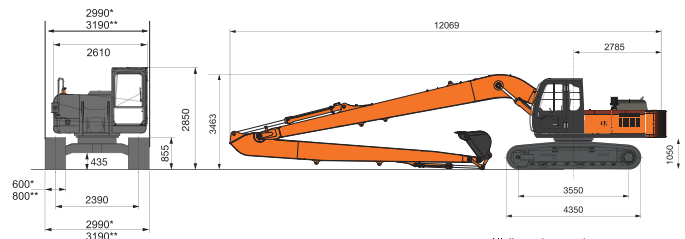

All dimensions are in mm
 *Machine with 600 mm track chain
 **Machine with 800 mm track chain

Tata Hitachi Construction Machinery Company Private Limited

Registered Office: Jubilee Building, 45 Museum Road, Bangalore, India 560025
 Telephone: +9180 66953301 / 02 / 03 / 04 / 05 | Email: info@tatahitachi.co.in



OUR RANGE OF PRODUCTS

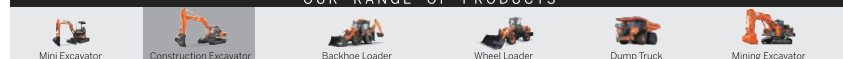

Authorised Dealer

These specifications are subject to change without prior notice. The machine depicted may vary from the actual machine. Please contact our nearest office for latest specifications. Accessories shown here are not part of the standard equipment. Performance of the machine may vary with site and operating conditions encountered.